



HVLP AIR CAP AND FLUID NOZZLE CHART

MODEL NO.	AIR CAPS	Press / Siphon	*MAX GUN INLET PRESS. FOR HVLP	FAN CONTROL	SCFM @ MAX GUN INLET	AIR CAP RING	AVAILABLE FLUID NOZZLES TIPS	NEEDLES / marking on needle
L300H	23-1008	pressure	40**	60-1502 (#2)	13.5	Included	33-0208 0.8mm (.022")	40-1308 (308)
	23-1010	pressure	40**		13.5		33-0210 1.0mm (.040")	40-1310 (310)
	23-1012	pressure	40**		13.5		33-0212 1.2mm (.046")	40-1312 (312)
	23-1013	pressure	40**		13.5		33-0213 1.3mm (.052")	40-1313 (313)
	23-1014	pressure	40**		13.5		33-0214 1.4mm (.055")	40-1314 (314)
	23-1015	pressure	40**		13.5		33-0215 1.5mm (.059")	40-1315 (315)
	23-1017	pressure	40**		13.5		33-0217 1.7mm (.070")	40-1317 (317)
	23-1019	pressure	40**		13.5		33-0219 1.9mm (.075")	40-1319 (319)
23-1022	pressure	40**	13.5	33-0222 2.2mm (.086")	40-1322 (322)			

*Note: Air cap test gages are available to confirm HVLP compliance.

**When using optional gun regulator, inlet pressure changes to 45psi

CONVENTIONAL AIR CAP AND FLUID NOZZLE CHART

MODEL NO.	AIR CAPS	Press / Siphon	*SUGGESTED GUN INLET PRESS.	FAN CONTROL	SCFM	AIR CAP RING	AVAILABLE FLUID NOZZLES	NEEDLES / marking on needle
L300C				60-1500		23-0201 included	33-0608 0.8mm (.022")	40-1308 (308)
	23-2010*	p/s	45-55		9-10.7		33-0610 1.0mm (.040")	40-1310 (310)
	23-2013*	p/s	45-55		9-10.7		33-0613 1.3mm (.052")	40-1313 (313)
	23-2014*	p/s	45-55		9-10.7		33-0614 1.4mm (.055")	40-1314 (314)
	23-2016*	p/s	45-55		9-10.7		33-0615 1.5mm (.059")	40-1315 (315)

Actual fluid nozzle and air cap combinations are determined by application (see application chart page 4)

*Gun inlet pressures may vary as required by application

Operation and Maintenance Instructions for *L300* Spray Guns

Operation

1. Connect air supply hose at handle of gun.
2. Connect a pressurized fluid supply or paint siphon cup to the gun fluid inlet.
3. Fluid flow can be controlled using the fluid control knob, this restricts flow by limiting needle travel. It is best to control fluid flow by proper selection of fluid orifice size and use the fluid control knob to “fine tune flow rate”.
4. Fan width can be adjusted using the fan control knob. Turning the knob clockwise narrows the fan.

Maintenance

IMPORTANT! Routine cleaning and maintenance is essential to insure proper gun operation.

Several states prohibit spraying solvent into the atmosphere and require the use of covered gun cleaner.

1. If a gun cleaner is being used, connect and clean the gun in the gun cleaner according to the manufactures instructions.
2. If a gun cleaner is not being used:
For pressure setups, remove air cap and clean separately using clean solvent.
Connect a pressurized solvent supply to the fluid inlet, trigger the gun allowing solvent to flow thru the gun until clean.
For siphon setups, first clean the siphon cup thoroughly then spray clean solvent thru the gun until clean.

NOTE: Gun head disassembly is not recommended for normal cleaning and maintenance.

Gun head disassembly and reassembly instructions:

Gun head disassembly

To remove the nozzle carrier (5) and air cap adapter (7):

1. Remove the air cap (2), fluid nozzle tip (3), fluid nozzle body (4), and needle (14)
2. Remove the needle seal cartridge (24)
3. Loosen the locknut (10) and remove fluid inlet (11) using a 5/8” open-end wrench
4. The nozzle carrier and air cap adapter will now slide forward from the gun body (12).

Gun head reassembly

1. Install a new o-ring (8) on the air cap adapter.
2. Install a new o-ring (6) onto the air cap adapter.
3. Install the thread locknut (10) onto the fluid inlet as far as possible.
4. Slide the nozzle carrier (5) into air cap adapter (7) and insert into the gun body as far as possible. Be sure the nozzle carrier extends into the hole at the back of the gun head. Install the needle seal (24) but do not tighten.
5. Rotate the nozzle carrier until the fluid inlet port in the nozzle carrier is aligned with the threaded hole in the body. While in this position, insert the fluid inlet (11) and tighten firmly.
6. Tighten the needle seal (24) to approx. 12 ft.-lb. torque.
7. Tighten the fluid inlet (11) to approx. 25 ft.-lb. torque.
8. Tighten the locknut (10) to approx. 33 ft.-lb. torque.

ITEM NUMBER	PART NUMBER	DESCRIPTION
1	See Air Cap Chart	Air Cap Ring
2	See Air Cap Chart	Air Cap
3	See Air Cap Chart	Fluid Nozzle Tip
4	See <i>LYNX</i> Model no.	Fluid Nozzle Body
5	See <i>LYNX</i> Model no.	Nozzle Carrier
6	See <i>LYNX</i> Model no.	Gasket*
7	See <i>LYNX</i> Model no.	Air Cap Adapter
8	See KIT NO. 10-106	O-Ring*
9	60-124	Fluid Inlet Seal
10	60-128	Locknut
11	60-126	Fluid Inlet Fitting
12	60-1114	<i>LYNX</i> Gun body HVLP
	60-1124	<i>LYNX</i> Gun body CONV.
13	See Air Cap Chart	Fan Control Assembly
14	See Air Cap Chart	Fluid Needle
15	60-202	Fluid Control Knob
16	See KIT NO. 10-106	Spring Seat*
17	See KIT NO. 10-106	Needle Return Spring*
18	60-201	Rear Bushing
19	See KIT NO. 10-106	Seal*
20	60-1520	Air Valve Assembly
21	60-302**	Air Valve Poppet
22	See KIT NO. 10-106	O-Ring*
23	See KIT NO. 10-106	Air Valve Spring*
24	60-1400*	Needle Seal Cartridge
25	60-2101	Trigger
26	60-1510	Air Control
26A	60-122	Plug (optional)
27	60-104	Air Inlet Fitting
28	60-1033	Trigger Pivot Set
29	98-109	Allen Plug

<i>LYNX</i> MODEL NO.	ITEM 4	ITEM 5	ITEM 6	ITEM 7
L300C	33-2201	60-L31C	98-8024*	60-32C
L300H	33-1201	60-L31H	98-8026*	60-34H

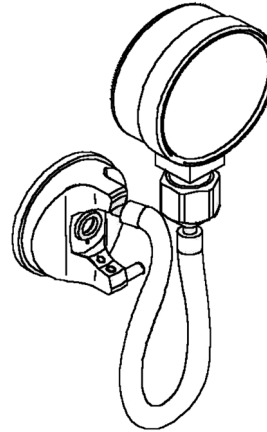

HVLP AIR CAP TEST GAGES	
FOR L300H GUNS	21-1010-G
	21-1013-G
	21-1014-G
	21-1015-G
	21-1017-G
	21-1019-G
	21-1022-G

* Included in KIT NO. 10-106

** Included with Air Valve Assembly 60-1520

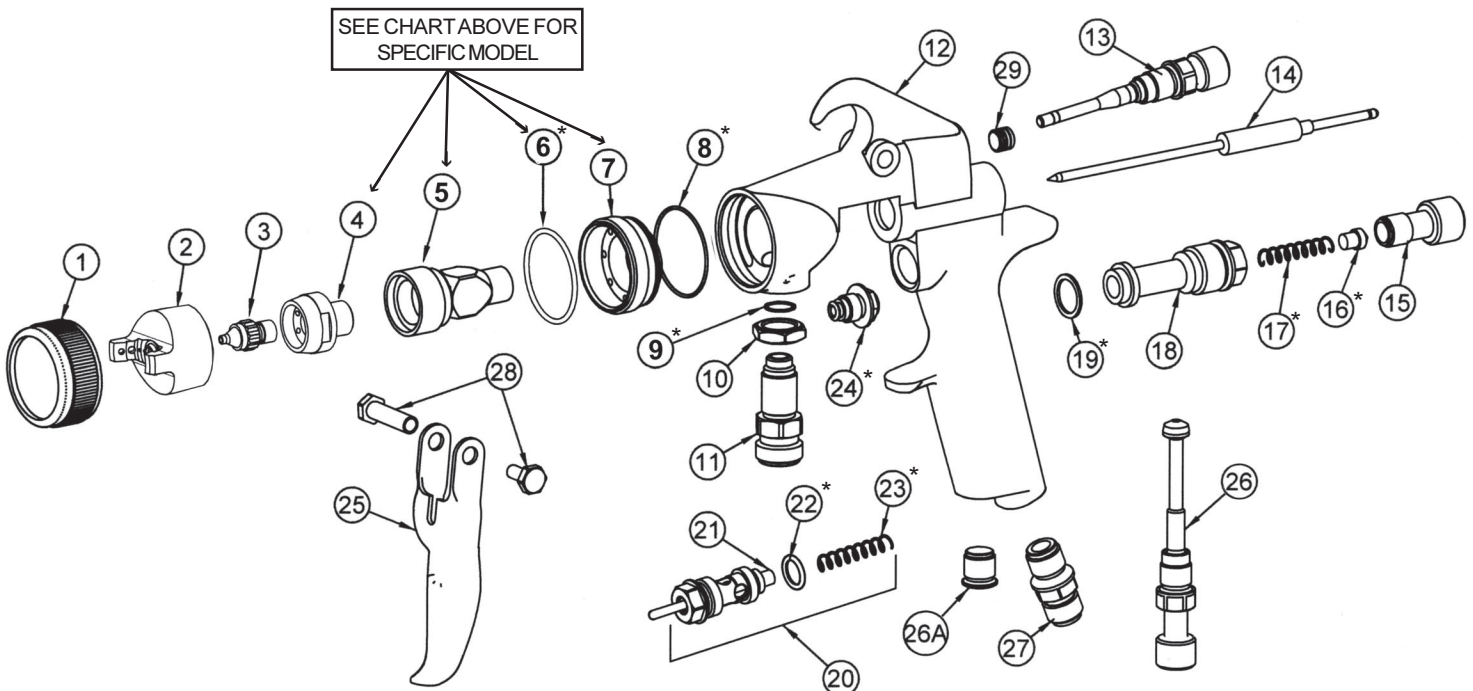

FLUID NOZZLE / AIR CAP SELECTION CHARTS

LYNX SERIES 300 - Pressure / Siphon Feed Guns

L300H HVLP SPRAY GUN

MATERIAL TYPE	FLUID ORIFICE x AIR CAP	MAXIMUM PATTERN WIDTH	PRESS. / SIPHON
Very Thin less than 16 sec. Zahn #2 inks , dyes, solvents, stains	1.0 mm x 1010	12	P
Thin 16 to 20 sec. Zahn #2 lacquers, enamels, primers, sealers	1.0 mm x 1010	12	P
	1.3 mm x 1013	12	P
Medium 21 to 30 sec. Zahn #2 automotive base coat enamels, primers epoxies, urethanes automotive clear coat	1.3 mm x 1013	12	P
	1.5 mm x 1015	12	P
	1.7 mm x 1017	12	P
Heavy over 30 sec. Zahn #2 heavy body primers high solid enamels high solid automotive coatings adhesives	1.5 mm x 1015	12	P
	1.7 mm x 1017	12	P
	1.9 mm x 1019	12	P
	2.2 mm x 1022	12	P

L300C CONVENTIONAL SPRAY GUN

MATERIAL TYPE	FLUID ORIFICE x AIR CAP	MAXIMUM PATTERN WIDTH	PRESS. / SIPHON
Very Thin less than 16 sec. Zahn #2 inks , dyes, solvents, stains	0.8 mm x 2010	12	P/S
	1.0 mm x 2010	12	P/S
Thin 16 to 20 sec. Zahn #2 lacquers, enamels, primers, sealers	0.8 mm x 2010	12	P/S
	1.0 mm x 2010	12	P/S
	1.3 mm x 2013	12	P/S
Medium 21 to 30 sec. Zahn #2 automotive base coat enamels, primers epoxies, urethanes automotive clear coat	1.3 mm x 2013	12	P/S
	1.4 mm x 2014	12	P/S
	1.6 mm x 2016	12	P/S
Heavy over 30 sec. Zahn #2 heavy body primers high solid enamels high solid automotive coatings adhesives	1.4 mm x 2014	12	P/S
	1.6 mm x 2016	12	P/S