

The C14 AAA pump system is an air assisted airless unit which combines airless and conventional or HVLP air atomization technologies to produce a very soft yet highly atomized spray pattern suitable for fine finish and high production work. The soft spray pattern has minimal over-spray and results in excellent material transfer efficiency.



Training videos are available at:
<http://www.spraycat.com/trainingvideos.html>

IMPORTANT! READ THE HAZARD WARNING INFORMATION

AIR ASSIST AIRLESS OPERATES WITH FLUID PRESSURES UP TO 1500 PSI AND CAN CAUSE SERIOUS INJURY IF IMPROPERLY USED. EVERYONE USING THIS EQUIPMENT MUST READ AND FULLY UNDERSTAND THE SAFETY WARNINGS. CALL WITH ANY QUESTIONS.

Wagner Spray Tech Corporation
Industrial Solutions Division
337 S. Arthur Ave.
Louisville, CO 80027

Tel: 303.438.5707
Toll: 888.820.4498
Fax: 303.438.5708
www.spraycat.com



Hazard Warnings

General Safety

The C14 AAA system is intended to be used by professional personnel only. Everyone using this equipment should read and understand all safety warnings.

1. Do not exceed the maximum working pressure of this equipment. MAXIMUM WORKING PRESSURE IS 1500 PSI FLUID PRESSURE (107 psi to air motor).
2. Do not modify this equipment.
3. Always relieve fluid pressure to 0 psi before performing maintenance.
4. Make sure all fluid connections are tight before operating this equipment
5. Operate this equipment only in a well ventilated area to prevent build up of toxic and or flammable fumes.

Fluid Injection Hazard

1. High fluid pressure can cause serious injury if injected into skin.
2. NEVER aim the spray gun at part of the body or at anyone.
3. NEVER put a hand or fingers on or near a leaking hose, hose connection or the gun spray tip.
4. ALWAYS use gun fluid shut off knob when not spraying.
5. IF FLUID INJECTION SHOULD OCCUR, IMMEDIATELY SEEK MEDICAL ATTENTION!

Toxic Fume and Fluid Hazard

1. Inhalation of toxic fumes and skin exposure to some chemicals can be a serious health hazard.
2. Read all manufacturers information for the material being sprayed, including material safety data sheets (MSDS sheets) and warnings.
3. Be sure recommended protective clothing and eye protection are used.
4. Wear a respirator or particle mask appropriate for material being sprayed.
5. Store all materials and solvents in accordance with manufacturers recommendations of local, and state safety codes.

Possible Fire or Explosion Hazard

1. Static sparks can cause fire or explosion.
2. The C14 AAA system is equipped with a grounding wire. Connect this wire to an appropriate earth ground source. Also ground objects being sprayed.
3. DO NOT operate this equipment near pilot lights, open flames or anyone smoking.
4. Keep spray area clear and free of combustible debris.

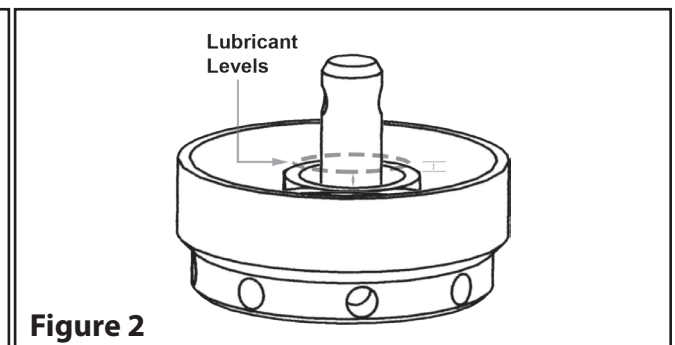
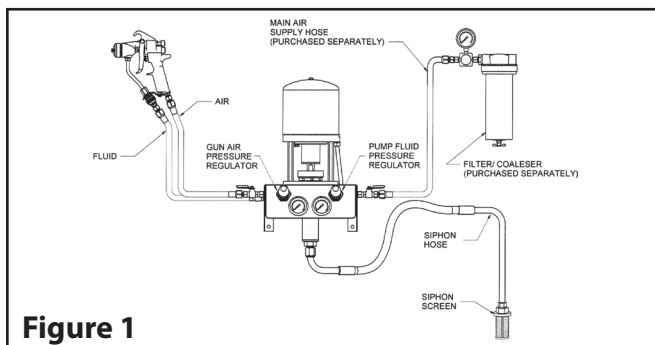

Setup

1. Back the pump pressure regulator completely off (counterclockwise) and close the ball valve. Attach the main air supply hose to ball valve on the pump fluid pressure regulator.
2. Attach fluid hose (BLUE HOSE) at pump outlet and gun fluid inlet.
3. Attach gun air hose (RED HOSE) to ball valve at gun pressure regulator and to air inlet on gun. Ball valve should be closed and regulator backed off.
4. Attach siphon hose to the pump inlet.
5. Make sure the fluid hose, air hose, and siphon hose connections are tight.
6. Insert siphon hose into an appropriate solvent to flush the pump before use and for additional setup requirements found in Steps 7-15.

Setup (Continued)

7. Test the pump in a safe controlled environment before using it for production. By doing so you will be able to detect and fix any potential leaks at the hose connections or in the fluid section upper seal. If you purchased a pump with the V-Packing upper seal assembly, please refer to Steps 8-14 for setting the seal prior to production.
8. For pumps with the V-Packing upper seal assembly, it's possible you will need to tighten the V packing adjustment nut 74-134 to reseal the upper V packings. These packings are adjusted at the factory for testing but can loosen over time and during shipment prior to use.
9. Refer to Steps 2-5 in the Operation section in order to test the tightness of the upper seal assembly.
10. Do not add the supplied throat seal lubricant to the lubricant cup as specified in Step 7 of the Operation section. It will be necessary to have a dry lubricant cup to see if any solvent flows into the cup.
11. Increase the fluid pressure to 20psi on the fluid pressure regulator. With the tip and air cap on the gun, test spray with solvent into a properly vented spray booth. Spray enough solvent for the pump to stroke 10 times. Check for visible leaks at fluid hose connection and check to see if there is solvent in the lubricant cup. If any solvent is present in the cup, dry the cup with a clean rag continue to Steps 12-15.
12. If solvent is present in the lubricant cup, depressurize the pump by first turning the fluid pressure regulator fully counter-clockwise. Remove the air cap and tip from the spray gun. Next relieve the fluid pressure by triggering the spray gun into a grounded material container. Be careful, when you trigger the gun there is still fluid pressure present. Solvent can splash back so be sure to wear protective goggles to avoid getting harmful solvent in your eyes. The fluid pressure gauge should now read zero and there should be no pressure on the system.
13. Tighten the 74-134 V-packing adjustment nut with a 11/16" wrench. Only tighten one full revolution at a time. Over tightening can cause the seal to restrict movement of the pump rod therefore stopping the air motor.
14. Repeat Steps 2-5 in the Operation section. Increase the fluid pressure to 20psi on the fluid pressure regulator and check to see if there is solvent in the lubricant cup. If not, the seal is most likely properly set at 20psi. Increase the pump pressure to 30psi and check to see if there is solvent in the lubricant cup. If there is, repeat Steps 12-13 to tighten the V-packing adjustment nut. Repeat Steps 12-13 until you see no visible solvent in the lubricant cup.
15. Now that the V-packing assembly is properly adjusted and set, completely flush the solvent out of the pump and move to the Operation section. Once the lubricant cup is properly filled, insert the siphon hose into the coating to be sprayed. Follow Steps 2-6 in the Operation section to load the pump with the coating to be sprayed.

Operation

1. Remove air cap and fluid tip from spray gun.
2. Turn pump fluid pressure ball valve on and slowly increase pressure on regulator until pump begins to stroke.
3. Direct spray gun discharge into material container. Trigger the spray gun and hold open until fluid is flowing from gun. Release the spray gun trigger and pump will stop. Pump is now primed.
4. Replace the fluid tip and air cap on spray gun.
5. With the spray gun triggered, increase pressure on pump until a fan pattern appears at the spray tip.
6. Open the ball valve at the gun pressure regulator. Increase the atomizing air pressure to the gun until the spray pattern is even and no longer has tails.
7. It is recommended that a lubricant (P/N: 91-36) compatible with the material being sprayed be used in the pump lubricant cup. This will increase pump seal life and minimize down time. See Figure 2 on page 2 for liquid levels.

NOTE: For HVLP compliance, maximum pressure setting on gun regulator is 15 psi. Pump pressure may be increased to eliminate tails in pattern.

Shutdown

For Short Term Shut Down:

1. Close the pump pressure ball valve and relieve pressure by triggering the spray gun.

For Long Term Shut Down:

1. Remove air cap and fluid tip from spray gun and close ball valve on gun pressure regulator.
2. Remove siphon hose from material.
3. Back pump pressure regulator off completely.
4. With the spray gun triggered and directed into the material container, slowly increase pressure on pump until pump strokes slowly. Continue until all material is returned to container.
5. Immerse siphon hose in a clean compatible solvent. Circulate solvent thru system until completely clean.
6. Purge solvent from system by removing siphon hose from solvent and continuing to operate pump until system is empty. Stop pump with pump rod in down position.

C14 Air Assist Airless System Components

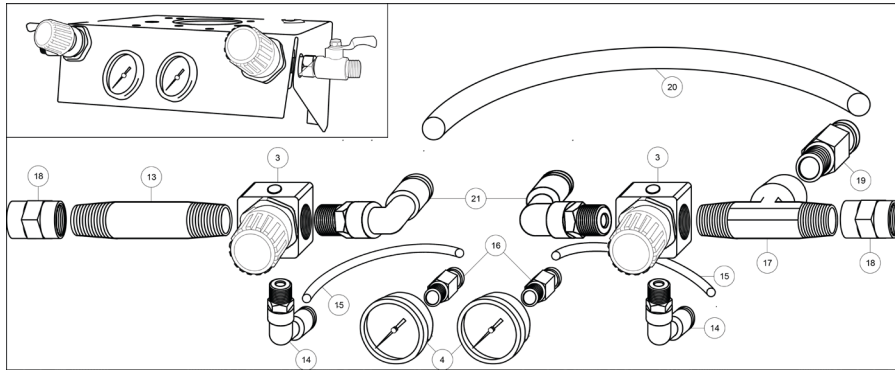
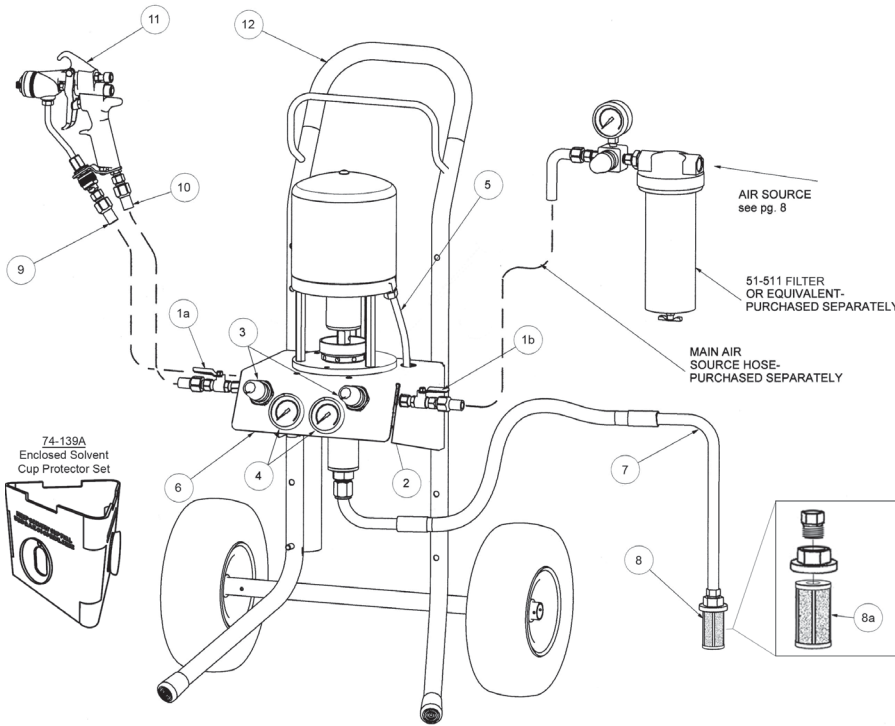

Fluid Tip Selection Chart

Std. Tip #	Opti-Tip #	Orifice Size	Fan Width*
36-207	36-207-F	0.007	4"
36-409	36-409-F	0.009	8"
36-311	36-311-F	0.011	6"
36-411	36-411-F	0.011	8"
36-511	36-511-F	0.011	10"
36-611	36-611-F	0.011	12"
36-413	36-413-F	0.013	8"
36-513	36-513-F	0.013	10"
36-613	36-613-F	0.013	12"
36-415	N/A	0.015	8"
36-515	N/A	0.015	10"
36-615	N/A	0.015	12"
36-417	N/A	0.017	8"
36-517	N/A	0.017	10"
36-617	N/A	0.017	12"
36-619	N/A	0.019	12"

*Fan width is based on 10" gun to target distance. Material viscosity will influence fan width. **Opti-Tip is proven to help reduce micro-bubbles in primers and waterborne coatings and also provides optimized atomization of topcoats, primers and paints. Opti-Tips are available for orifice sizes 0.007 thru 0.013. Order P/N 36-XXX-F Opti-Tip.

Item No.	Part No.	Description	Item No.	Part No.	Description
1a	52-150	Ball Valve 1/4"	9	53-402	Fluid Hose Assembly 25ft. (BLUE HOSE)
1b	52-150	Ball Valve 1/4"	10	53-111-25	Air Hose Assembly 25ft. (RED HOSE)
2	75-138	Interconnect Tube Assembly	11	66-100	Cougar Gun (Less Air Cap and Fluid Tip)
3	52-6	Regulator Only	12	70-180	Cart Assembly
4	52-64	Pressure Gages Air Motor & Gun Air 0-100 psi	13	98-0273	1/4" Extension
5	75-146	Pump Protector Tube Assembly	14	53-528	Push on Hose Elbow 1/8"BSP X 6MM"OD Hose
6	70-170	Pump Mounting Bracket	15	53-29	6mm Tube (6 inches per section)
7	74-538	Siphon Hose Assy 5 Gallon (Std) 3/8" L Vol.	16	53-527	Push on Hose Fitting 1/8"NPTM X 1/4"OD Hose
	74-520*	Siphon Hose Assy 5 Gallon (Opt.) 1/2" H Vol.	17	98-0225	Brass T-Fitting
	74-524*	Siphon Hose Assy 55 Gallon (Opt.) 1/2" H Vol.	18	98-0387	1/4" Brass Coupling
8	74-510	Siphon Hose Strainer 3/8" (Standard)	19	53-525	Push on Hose Fitting 1/4"NPTM X 3/8"OD Hose
	74-511	Siphon Hose Strainer 1/2" (Standard)	20	53-25	3/8" Tube (12 inches per section)
8a	74-560	Strainer Screen	21	53-520	Push on Hose Elbow 1/4"NPTM X 3/8"OD Hose

NOTE: Fluid and air hoses (9 & 10) are wrapped together in a hose sleeve. Sleeve may be purchased separately as P/N 91-51.

* Siphon hoses 74-520 and 74-524 require 1/2" fluid inlet (P/N 74-118) see fluid section exploded view on page 6.

Operation and Maintenance for Cougar Spray Gun

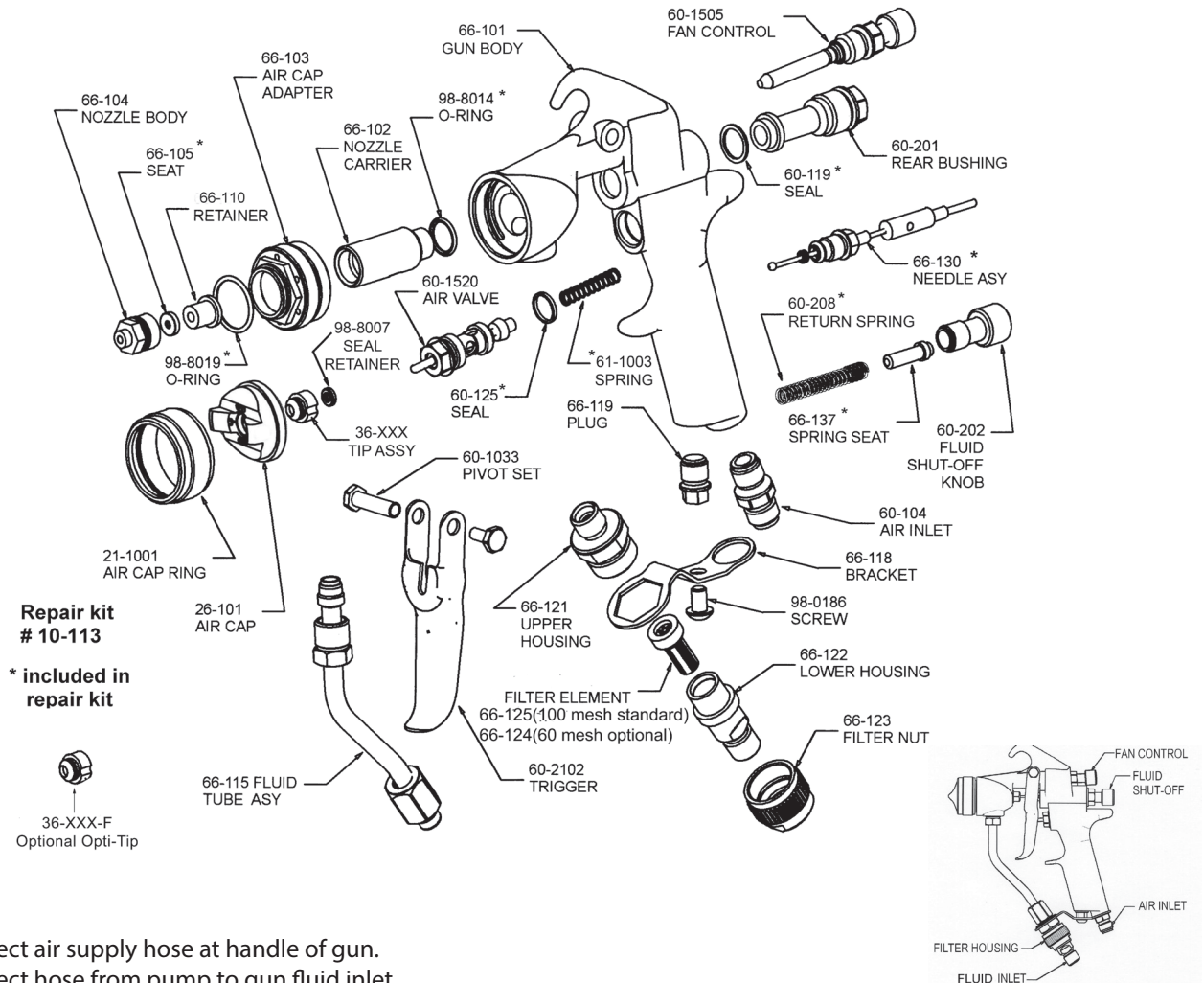

Operation

1. Connect air supply hose at handle of gun.
2. Connect hose from pump to gun fluid inlet.
3. The fluid shut-off knob locks the trigger and prevents gun operation when turned clockwise as far as possible.
4. Maximum pattern width is determined by tip selection. Turning the fan control knob counter clockwise will narrow the fan. Pattern is maximum when fan control knob is completely closed.
5. For HVLP compliance, do not exceed 15 psi air pressure at gun handle.

Maintenance

NOTE: Complete gun disassembly is not recommended for normal cleaning and maintenance.
IMPORTANT! Relieve gun fluid pressure to 0 psi before performing any maintenance.

Replacing Needle Assembly

1. Remove trigger.
2. Remove fluid shut-off knob by turning counter clockwise. Remove return spring and spring seat.
3. Using a 9/16" open end wrench or socket, remove rear bushing. Don't lose gasket, it can be reused.
4. Using a 3/8" open end wrench remove needle seal packing nut. The needle assembly can be removed thru back of gun.
5. When replacing spring seat, the long end goes inside spring for operating pressures below 1000 psi. For operating pressures above 1000 psi short end of spring seat goes into spring.

Replacing Gun Seat

1. Remove air cap and fluid tip. Using a 1/2" socket, remove fluid nozzle body.
2. Using a 3/32" rod or the end of the needle assembly push the seat and seat retainer out of nozzle body.

Replacing Gun Filter

1. Using a 3/4" open end wrench, remove filter retainer nut and separate upper and lower filter housings exposing the filter. It is not necessary to disconnect fluid hose to change filter.

Note: Gun is equipped with a 100 mesh filter. 60 mesh filters are also available.

C14 Air Assist Airless Fluid Section - 74-101/74-101P

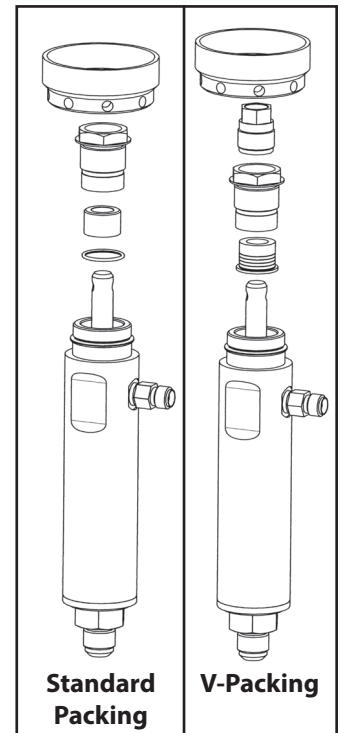
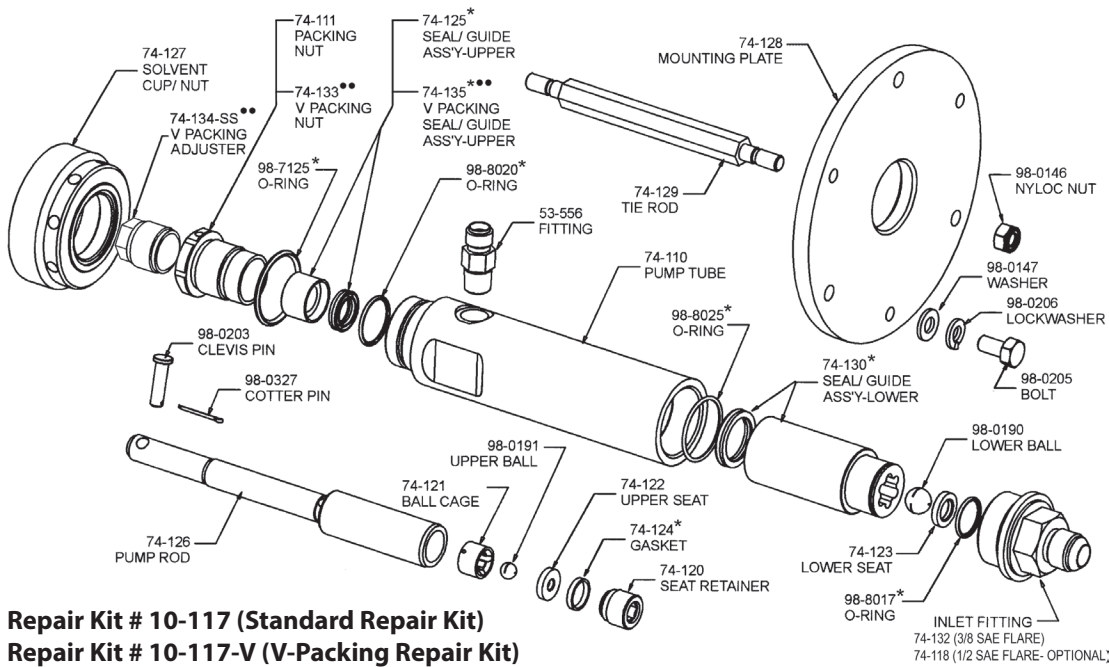

Repair Kit # 10-117 (Standard Repair Kit)
Repair Kit # 10-117-V (V-Packing Repair Kit)
***Included in repair kit**

Upgrade Kit # 74-136 (Converts Standard Packing models to V-Packing models)
****Included in Upgrade Kit (74-136)**

Disassembly from the Air Motor

Pump disassembly and service is easiest if first removed from air motor.

1. Disconnect the fluid hose and siphon hose from the pump.
2. Remove the cotter pin and clevis pin connecting the pump and air motor.
3. Leave mounting plate and tie rods attached to the air motor. Loosen and remove the solvent cup using the 1/4" pin wrench provided.

Pump Disassembly

It is recommended that repair kit #10-117 or 10-117-V be on hand before starting pump repair.

1. Holding the pump tube by the flats, remove the inlet fitting using an adjustable or 1 1/8" wrench. The lower ball and seat can be removed.
2. Push down on the pump rod from top of pump. The pump rod and lower seal/guide assembly will come out thru bottom of pump.
3. Remove the upper packing nut using an adjustable or 1 1/8" wrench. The upper seal/guide will come out with the upper packing nut.
4. Place one end of the 1/4" pin wrench thru the clevis pin hole in the pump rod. Using a 3/8" hex wrench remove the upper seat retainer. The upper seat, ball, and ball cage can be removed.

Pump Reassembly

1. Inspect the pump rod in the areas where the upper and lower seals ride. If the diameter of the rod in these areas appear to be reduced or if scoring has occurred, the rod must be replaced. Replace the upper ball and seat into the rod using a clean ball and seal. Note, the seat is reversible.
2. Replace the upper seal/guide in the upper packing nut. Replace the o-ring (98-8020) on pumps with standard packings only. Place upper packing nut into pump tube and tighten.
3. Place the lower end of the pump rod into a new lower seal/guide assembly and new o-ring (98-8025). Carefully slide upper end of pump rod into pump tube and thru the upper seal/guide.
4. Place a new o-ring (98-8017) around the lower seat (Note, seat is reversible) and push into the recess in the inlet fitting. Set a clean ball on the seat and tighten inlet fitting into the pump tube.
5. Replace o-ring (98-7125) on pump tube and slide pump thru mounting plate and solvent cup. Orient the outlet fitting as desired and tighten the solvent cup to secure pump. Reattach the pump to the air motor by replacing the clevis pin and cotter pin.

C14 Air Assist Airless Air Motor - 75-100

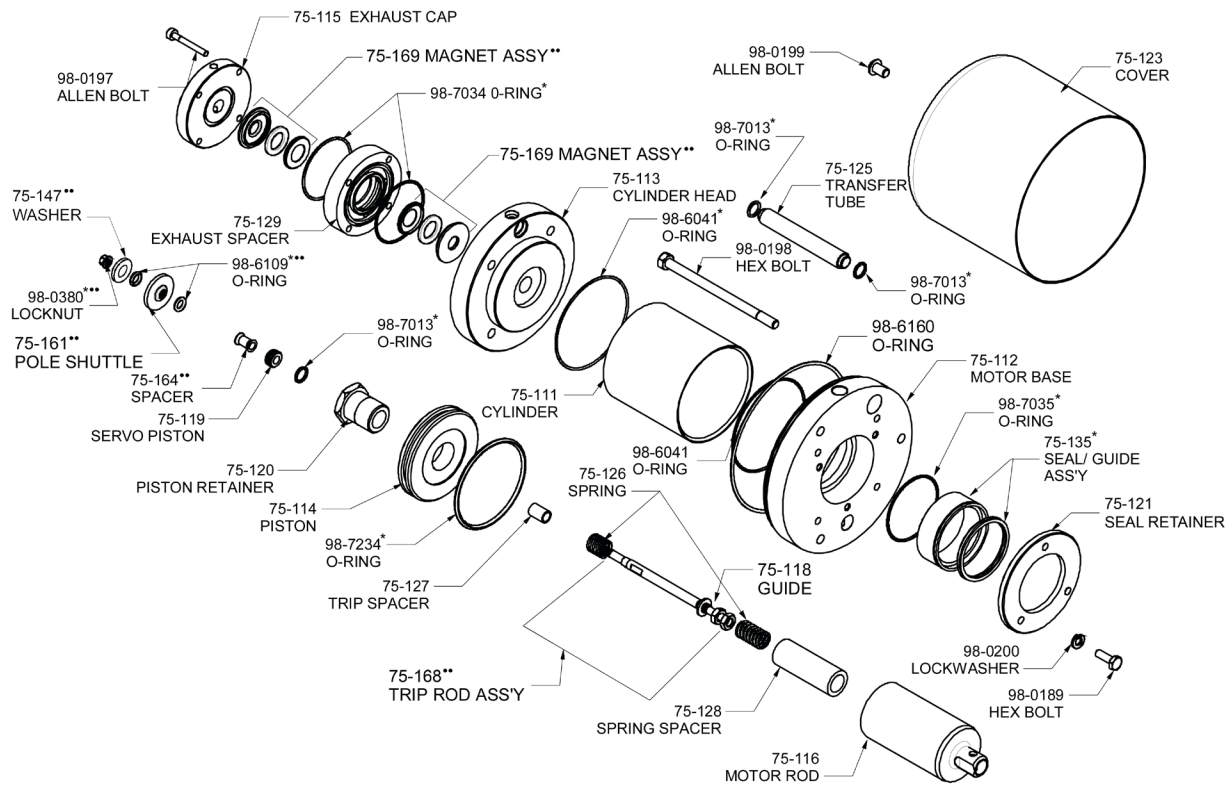

Repair Kit #10-163

*Included in repair kit (10-163)

Upgrade Kit #10-165 (Converts any old model 14:1 pump to the new PEAK Model)

**Included in Upgrade Kit (10-165)

Replacing the Air Motor Rod Seal/Guide Assembly

The main air motor rod seal/guide assembly can be replaced without major disassembly of air motor.

1. Push the air motor rod up as high as possible.
2. Using a 7/16" wrench, remove the three hex head bolts and remove the seal retainer plate. The exposed end of the guide has a groove. Using two screw drivers, engage the groove and pry the seal/guide assembly out.
3. Lubricate o-ring (98-7035) and the new seal/guide assembly with petroleum jelly. Insert over air motor rod and into gland cavity. Caution! Use care not to damage seal lips.
4. Replace the retainer plate and three retainer plate screws.

Complete Air Motor Disassembly

It is recommended that repair kit # 10-163 be on hand before starting pump repair.

1. Remove the air motor cover using a 1/4" hex wrench.
2. Remove the four allen head bolts (98-0197).
3. Remove the exhaust cap, valve plate, and exhaust spacer.
4. Push the air motor rod to the up position. Lift up on locknut (98-0380) until a flat on the trip rod is exposed just outside the top cylinder head. Using a 1/4" open end wrench on the trip rod and a second 5/16" wrench on the locknut, remove the locknut.
5. Continue holding the trip rod and unscrew the magnet assembly. Remove the spacer and servo piston. Note: Wrap the magnet assembly in a clean paper towel as it will attract any nearby magnetic debris.
6. Using a 1/2" wrench, remove the four hex head bolt holding retaining the cylinder head. Remove the cylinder head, cylinder and transfer tube.
7. Push the air motor rod out of the motor base. Using a 5/8" open end wrench on the air motor rod and a 1 1/4" wrench, remove the piston retainer. The trip rod and trip springs can be removed for inspection.
8. See instructions above for removal and replacement of the seal/guide assembly in the motor base.
9. Reassemble air motor in reverse order. Lubricate all o-rings using petroleum jelly during reassembly.
10. Add 1 drop of CAPPlus 71TL thread locker to the trip rod assembly threads before installing magnet assembly.

Cougar Gun Air Consumption

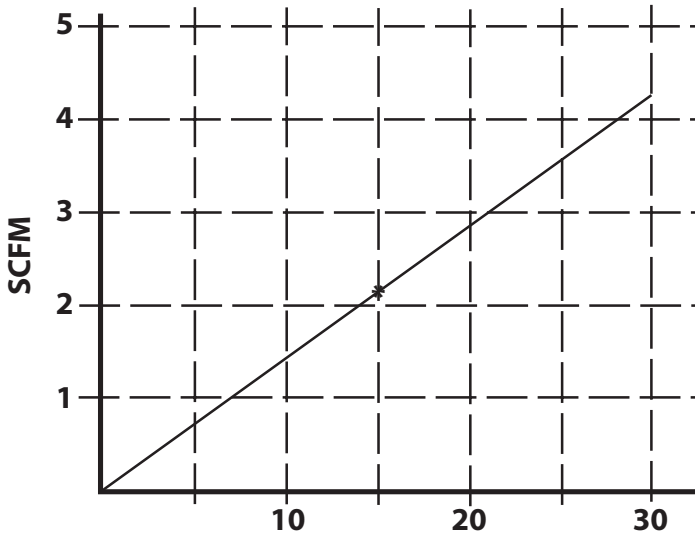

Gun Regulator Pressure (PSI)

*Max pressure for HVLP

C14 AAA Pump Air Consumption

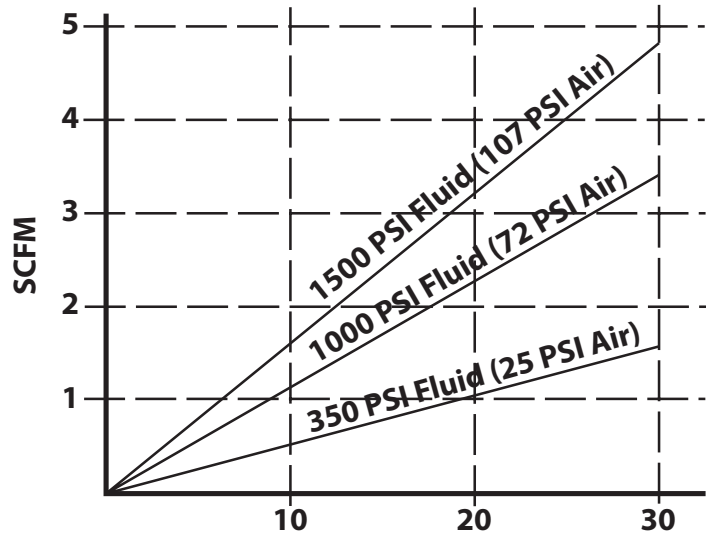

Pump Speed (Cycles Per Minute)

13 26 39

Pump Speed (Ounces Per Minute)

Compressed Air Requirements

Minimum compressor size will vary with the application. Air requirements for the gun and pump must be added together for total air requirements.

Example: Gun Regulator Setting 25 psi, scfm = 3.5
 Pump fluid pressure is 1000 psi and cycle rate is 30, scfm = 1.75
 Minimum compressor requirement: 3.5+1.75 = 5.25 scfm

Fluid Tip Flow Rate Chart (Fluid oz/min.)

Tip Size	Pressure - 350 (PSIG)		Pressure - 700 (PSIG)		Pressure - 1000 (PSIG)		Pressure - 1500 (PSIG)	
	Light Materials	Heavy Materials	Light Materials	Heavy Materials	Light Materials	Heavy Materials	Light Materials	Heavy Materials
0.007	3	-	4	-	5	-	6	-
0.009	5	-	8	-	9	-	11	-
0.011	8	-	11	-	13	-	16	-
0.013	10	-	14	-	17	-	21	-
0.015	13	-	18	-	22	-	27	-
0.017	17	13	24	18	29	22	35	27
0.019	21	16	30	23	36	27	44	33
0.021	27	21	38	29	45	35	56	43

Note: Values are approximate and will vary depending on actual material viscosity



Training videos are available at:
<http://www.spraycat.com/trainingvideos.html>